



**INSTYTUT TECHNIKI BUDOWLANEJ**  
PL 00-611 WARSZAWA  
ul. Filtrowa 1  
tel.: (+48 22) 825-04-71  
(+48 22) 825-76-55  
fax: (+48 22) 825-52-86  
[www.itb.pl](http://www.itb.pl)



Member of



## European Technical Assessment

**ETA-18/0433  
of 04/06/2018**

### General Part

**Technical Assessment Body issuing the European Technical Assessment**

Instytut Techniki Budowlanej

**Trade name of the construction product**

TAP CE

**Product family to which the construction product belongs**

Deformation-controlled expansion anchors for multiple use for non-structural applications in concrete

**Manufacturer**

FRIULSIDER S.p.A  
Via Trieste 1  
I-33048 San Giovanni al Natisone (UD)  
Italy

**Manufacturing plant(s)**

Plant 1

**This European Technical Assessment contains**

10 pages including 3 Annexes which form an integral part of this assessment

**This European Technical Assessment is issued in accordance with Regulation (EU) No 305/2011, on the basis of**

Guideline for European Technical Approval ETAG 001, Edition April 2013 "Metal anchors for use in concrete – Part 1: Anchors in general and Part 6: Anchors for multiple use for non-structural applications", used as European Assessment Document (EAD)

*This European Technical Assessment is issued by the Technical Assessment Body in its official language. Translations of this European Technical Assessment in other languages shall fully correspond to the original issued document and should be identified as such.*

*Communication of this European Technical Assessment, including transmission by electronic means, shall be in full. However, partial reproduction may be made, with the written consent of the issuing Technical Assessment Body. Any partial reproduction has to be identified as such.*

## Specific Part

### 1 Technical description of the product

The TAP CE are deformation-controlled expansion anchors. The anchors are made of zinc plated steel.

The anchor is installed in a drilled hole and anchored by deformation-controlled expansion.

The description of the product is given in Annex A.

### 2 Specification of the intended use in accordance with the applicable European Assessment Document (EAD)

The performances given in Section 3 are only valid if the anchors are used in compliance with the specifications and conditions given in Annex B.

The performances given in this European Technical Assessment are based on an assumed working life of the anchor of 50 years. The indications given on the working life cannot be interpreted as a guarantee given by the producer or the Technical Assessment Body, but are to be regarded only as a means for choosing the right products in relation to the expected economically reasonable working life of the works.

### 3 Performance of the product and references to the methods used for its assessment

#### 3.1 Performance of the product

##### 3.1.1 Mechanical resistance and stability (BWR 1)

Essential characteristic	Performance
Characteristic resistance for all load directions	See Annex C1
Edge distances and spacing	See Annex C1

##### 3.1.2 Safety in case of fire (BWR 2)

Essential characteristic	Performance
Reaction to fire	Anchors satisfy requirements for Class A1
Resistance to fire	See Annex C2

##### 3.1.3 Hygiene, health and the environment (BWR 3)

Regarding the dangerous substances clauses contained in this European Technical Assessment, there may be requirements applicable to the products falling within its scope (e.g. transposed European legislation and national laws, regulations and administrative provisions). In order to meet the provisions of the Construction Products Regulation, these requirements need also to be complied with, when and where they apply.

#### **3.1.4 Safety and accessibility in use (BWR 4)**

For Basic Requirement Safety in use the same criteria are valid as for Basic Requirement Mechanical resistance and stability (BWR 1).

#### **3.1.5 Sustainable use of natural resources (BWR 7)**

No performance assessed.

#### **3.1.6 General aspects relating to fitness for use**

Durability and serviceability are only ensured if the specifications of intended use according to Annex B1 are kept.

#### **3.2 Methods used for the assessment**

The assessment of fitness of the anchors for the declared intended use in relation to the requirements for mechanical resistance and stability and safety in use in the sense of the Basic Requirements 1 and 4 has been made in accordance with the ETAG 001 "Metal anchors for use in concrete", Part 1: "Anchors in general" and Part 6: "Anchors for multiple use for non-structural applications".

The assessment of the anchor for the intended use in relation to the requirements for resistance to fire has been made in accordance with the EOTA Technical Report TR 020 "Evaluation of anchorages in concrete concerning resistance to fire".

#### **4 Assessment and verification of constancy of performance (AVCP) system applied, with reference to its legal base**

According to Decision 97/161/EC of the European Commission the system 2+ of assessment and verification of constancy of performance (see Annex V to Regulation (EU) No 305/2011) applies.

#### **5 Technical details necessary for the implementation of the AVCP system, as provided for in the applicable European Assessment Document (EAD)**

Technical details necessary for the implementation of the AVCP system are laid down in the control plan which is deposited at Instytut Techniki Budowlanej.

For type testing the results of the tests performed as part of the assessment for the European Technical Assessment shall be used unless there are changes in the production line or plant. In such cases the necessary type testing has to be agreed between Instytut Techniki Budowlanej and the notified body.

Issued in Warsaw on 04/06/2018 by Instytut Techniki Budowlanej



Krzysztof Kuczyński, PhD  
Deputy Director of ITB

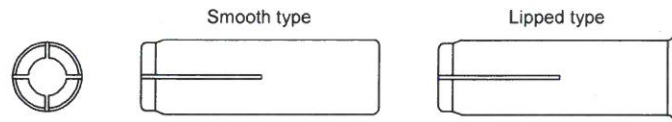

Marking on the body

1. Smooth type: TAP 06...12D
2. Lipped type: TAP 06L/TAP 12DL
3. M10x30 Lipped: TAP 10R

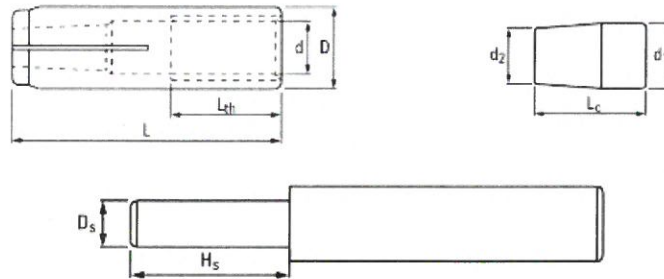
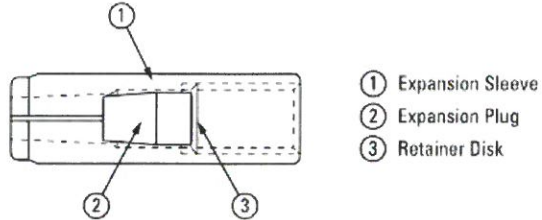

Dimensions			TAP CE06	TAP CE08	TAP CE10R	TAP CE10	TAP CE12	TAP CE12D
<b>Anchor size</b>								
<b>Expansion sleeve</b>								
Sleeve diameter	D	[mm]	8	10	12	12	15	16
Sleeve length	L	[mm]	25	30	30	40	50	50
Thread	d	[-]	M6	M8	M10	M10	M12	M12
Thread length	L <sub>th</sub>	[mm]	11	13	12	17	21	21
<b>Expansion plug</b>								
Plug diameter	d <sub>1</sub>	[mm]	5,0	6,5	8,0	8,0	10,1	10,1
Plug diameter	d <sub>2</sub>	[mm]	4,0	5,5	6,9	6,5	8,5	8,5
Plug length	L <sub>c</sub>	[mm]	10	12	11	15	20	20
<b>Installation pin</b>								
Setting pin diameter	D <sub>s</sub>	[mm]	4,8	6,6	7,8	7,8	9,6	9,6
Setting pin length	H <sub>s</sub>	[mm]	15	18	18	25	30	30
<b>Materials</b>								
<b>Element</b>	<b>Material</b>		<b>Protection</b>					
Expansion sleeve	Q195 acc. to GB/T 700		zinc coating (≥ 5 μm); electroplated acc. to EN ISO 4042					
Expansion plug	Q195 acc. to GB/T 700							

TAP CE

**Product description**  
Characteristic of the product

**Annex A1**  
of European  
Technical Assessment  
ETA-18/0433

### SPECIFICATION OF INTENDED USE

**Anchorage subject to:**

- Multiple use for non-structural applications. The definition of multiple use according to the Member States is given on the informative Annex 1 of ETAG 001, Part 6.
- Static and quasi-static loads.
- Anchorages with requirements related to resistance to fire.

**Base material:**

- Reinforced or unreinforced normal weight concrete of strength class C20/25 at minimum to C50/60 at maximum according to EN 206.
- Non-cracked and cracked concrete.

**Use conditions (environmental conditions):**

- Structures subject to dry internal conditions.

**Design:**

- Anchorages are designed under the responsibility of an engineer experienced in anchorages and concrete work.
- Verifiable calculation notes and drawings are prepared taking account of the loads to be transmitted. The position of the anchor is indicated on the design drawings (e.g. position of the anchor relative to reinforcement or to supports, etc.).
- Anchorages under static and quasi-static loads are designed in accordance with ETAG 001, Annex C, design method B, Edition August 2010.
- The design of anchorages under fire exposure has to consider the conditions given in the EOTA Technical Report TR 020.

**Installation:**

- Anchor installation carried out by appropriately qualified personnel and under the supervision of the person responsible for technical matters of the site.
- Use of the anchor only as supplied by the manufacturer without exchanging any component of the anchor.
- Anchor installation in accordance with the manufacturer's specifications and drawings and using the appropriate tools.
- Check of concrete being well compacted, e.g. without significant voids.
- Positioning of the drill holes without damaging the reinforcement.
- In case of aborted hole: new drilling at a minimum distance away of twice the depth of the aborted hole or smaller distance if the aborted drill hole is filled with high strength mortar and if under shear or oblique tension load it is not in the direction of load application.
- Anchor installation such that the effective anchorage depth is complied with.

<b>TAP CE</b>	<b>Annex B1</b> of European Technical Assessment ETA-18/0433
<b>Intended use Specification</b>	

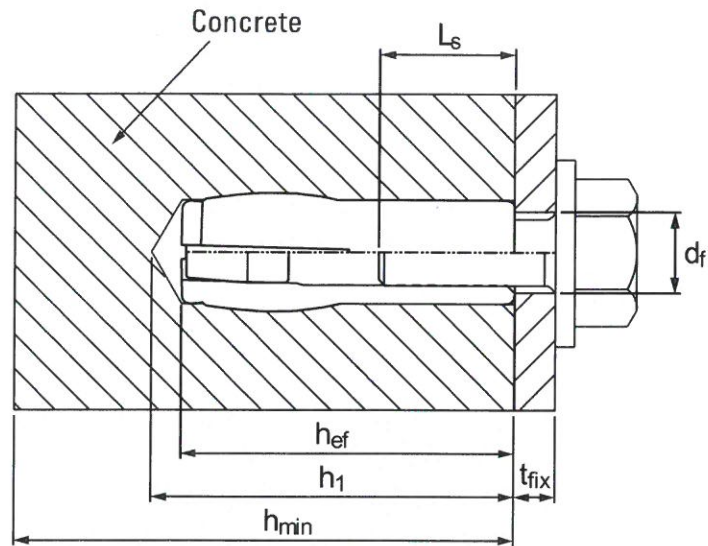

**Table B1:** Installation parameters

Anchor			TAP CE					
Size			TAP CE06	TAP CE08	TAP CE10R	TAP CE10	TAP CE12	TAP CE12D
Effective anchorage depth	$h_{ef}$	[mm]	25	30	30	40	50	50
Drill hole depth	$h_1$	[mm]	28	33	33	43	54	54
Drill hole diameter	$d_0$	[mm]	8	10	12	12	15	16
Installation torque (max)	$T_{inst}$	[mm]	4	8	15	15	35	35
Thickness of concrete member (min)	$h_{min}$	[mm]	80	80	80	80	100	100
Screwing depth (min)	$L_{s, min}$	[mm]	6	8	8	10	12	12
Screwing depth (max)	$L_{s, max}$	[mm]	11	13	12	17	21	21
Diameter of clearance hole in the fixture	$d_f$	[mm]	7	9	12	12	14	14
Spacing (min)	$s_{min}$	[mm]	200	200	200	200	200	200
Edge distance (min)	$c_{min}$	[mm]	150	150	150	150	150	150

Fastening screws or anchor threaded rods:

Steel, property class 4.6 / 4.8 / 5.8 / 6.8 / 8.8 according to EN-ISO 898-1; thickness of galvanizing  $\geq 5 \mu m$

**TAP CE**

**Intended use**  
Installation parameters

**Annex B2**  
of European  
Technical Assessment  
ETA-18/0433

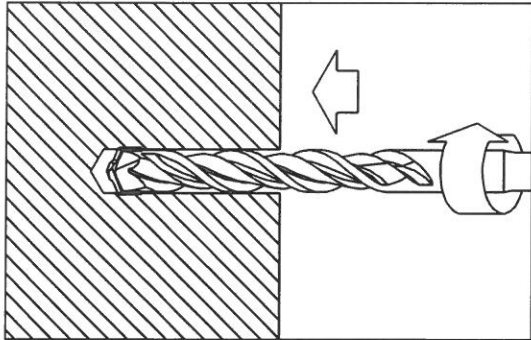

Drill hole with rotary percussive machine. Drill to a required depth.

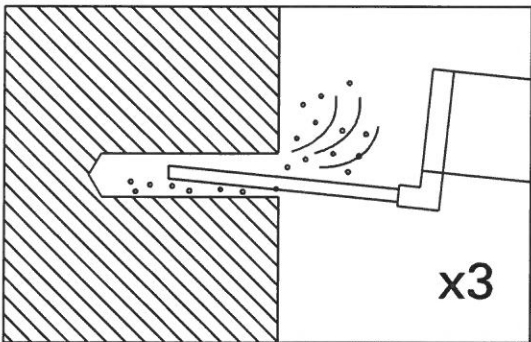

Blow out dust at least 3 times with a hand pump.

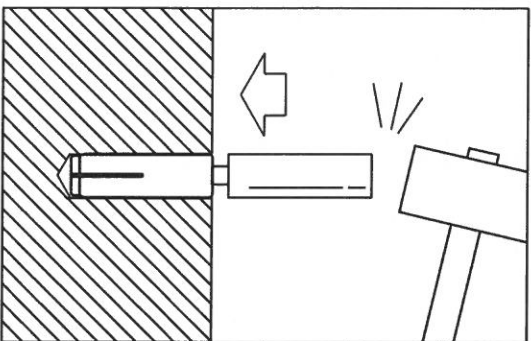

Put the anchor into the drill hole, hammering with the installation tool, until the setting pin fully insert into the anchor.

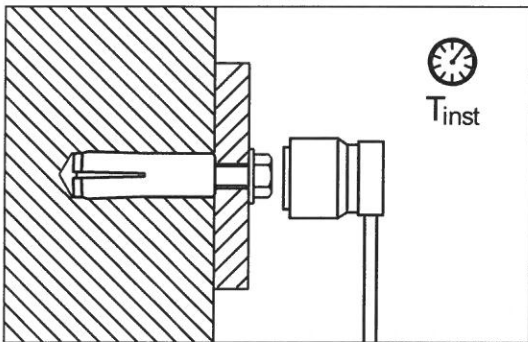

Fix the fixture by screw or threaded rod with max.  $T_{inst}$ .

**TAP CE**

**Intended use**  
Installation instruction and tools

**Annex B3**  
of European  
Technical Assessment  
ETA-18/0433



**Table C1:** Characteristic resistance in concrete C20/25 to C50/60 (design acc. to ETAG 001, Annex C, method B)

Anchor			TAP CE					
Size			TAP CE06	TAP CE08	TAP CE10R	TAP CE10	TAP CE12	TAP CE12D
<b>All load directions (fastening screw or threaded rod property class <math>\geq</math> 4.6)</b>								
Characteristic resistance in concrete C20/25 to C50/60	$F_{Rk}$	[kN]	1,5	2,0	3,0	3,0	4,0	5,0
Partial (installation) safety factor	$\gamma_2$	[-]	1,4	1,4	1,4	1,4	1,4	1,4
Spacing	$s_{cr}$	[mm]	200	200	200	200	200	200
Edge distance	$c_{cr}$	[mm]	150	150	150	150	150	150
Minimum member thickness	$h_{min}$	[mm]	80	80	80	80	100	100
<b>Shear load: steel failure with lever arm</b>								
Characteristic bending moment: screw class 4.6	$M_{Rk,S}^0$	[Nm]	6,1	15,0	29,9	29,9	52,4	52,4
Characteristic bending moment: screw class 4.8	$M_{Rk,S}^0$	[Nm]	6,1	15,0	29,9	29,9	52,4	52,4
Characteristic bending moment: screw class 5.8	$M_{Rk,S}^0$	[Nm]	7,6	18,8	37,4	37,4	65,6	65,6
Characteristic bending moment: screw class 6.8	$M_{Rk,S}^0$	[Nm]	9,2	22,5	44,9	44,9	78,7	78,7
Characteristic bending moment: screw class 8.8	$M_{Rk,S}^0$	[Nm]	12,2	30,0	59,9	59,9	104,9	104,9

TAP CE

**Performances**  
Characteristic resistance

**Annex C1**  
of European  
Technical Assessment  
ETA-18/0433

**Table C2:** Characteristic resistance under fire exposure in concrete C20/25 to C50/60 (design acc. to ETAG 001, Annex C, method B)

Anchor		TAP CE						
Size		TAP CE06	TAP CE08	TAP CE10R	TAP CE10	TAP CE12	TAP CE12D	
Fire resistance class (fastening screw or threaded rod property class $\geq 4.6$ )								
R30	Characteristic resistance $F_{Rk,fi}$ <sup>1)</sup>	[kN]	0,2	0,5	0,8	0,8	1,0	1,3
R60		[kN]	0,2	0,5	0,8	0,8	1,0	1,3
R90		[kN]	0,1	0,4	0,8	0,8	1,0	1,1
R120		[kN]	0,1	0,3	0,6	0,6	0,8	0,8
Spacing	$s_{cr,fi}$	[mm]	4 x $h_{ef}$					
Edge distance	$c_{cr,fi}$	[mm]	2 x $h_{ef}$					
The design method covers anchors with a fire attack from one side only. In case of fire attack from more than one side, the edge distance shall be $\geq 300$ mm. <sup>1)</sup> in the absence of other national regulations a partial safety factor $\gamma_{m,fi} = 1,0$ is recommended								

TAP CE

**Performances**  
Characteristic resistance under fire exposure

**Annex C2**  
of European  
Technical Assessment  
ETA-18/0433